

JUNO-106

SERVICE NOTES

First Edition

SPECIFICATIONS

KEYBOARD	61 keys, 5 octaves, C scale	ENV	
DCO		ATTACK TIME	1.5ms to 3s
TUNE	±50 cents	DECAY TIME	1.5ms to 12s
LFO MOD.	±400 cents	SUSTAIN LEVEL	0 to 100%
BENDER	±1200 cents	RELEASE TIME	1.5ms to 12s
VCF		LFO	
CUTOFF FREQ.	5Hz to 50kHz	RATE	0.1Hz to 30Hz
RESONANCE	0 to self oscillation	DELAY TIME	0 to 3s
ENV MOD.	±14 octaves	AUDIO OUTPUT	L: -30dBm; M: -15dBm;
LFO MOD.	±3.5 octaves		H: 0dBm
BENDER	±3.5 octaves	DIMENSIONS	992(W)x320(D)x120(H)mm
KEY FOLLOW	+3/-2 octaves		39-1/16(W)x12-5/8(D)x
			4-11/16(H) in.
		WEIGHT	10kg/22 lb.
		POWER CONSUMPTION	25W (20W-100V)

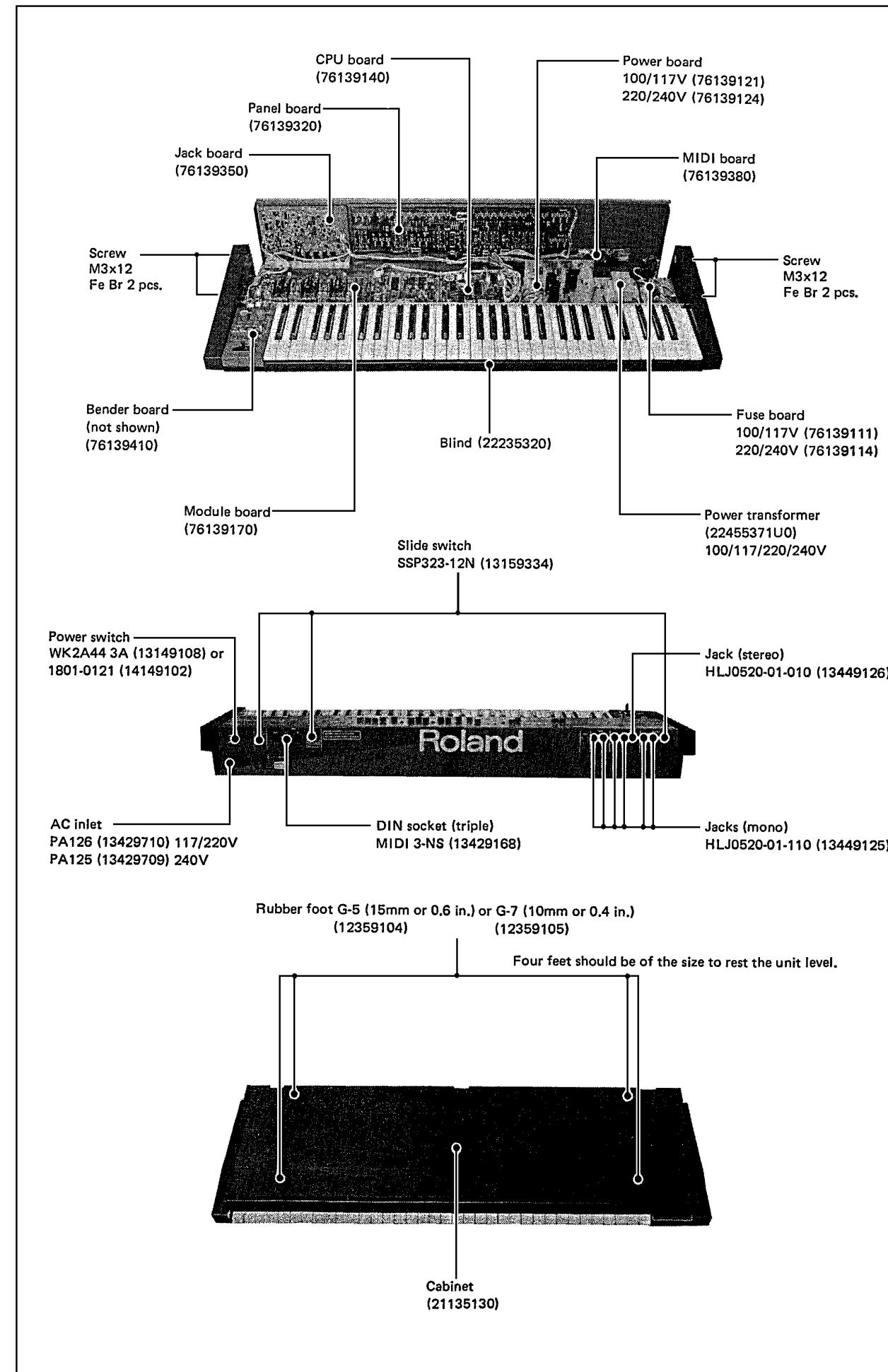
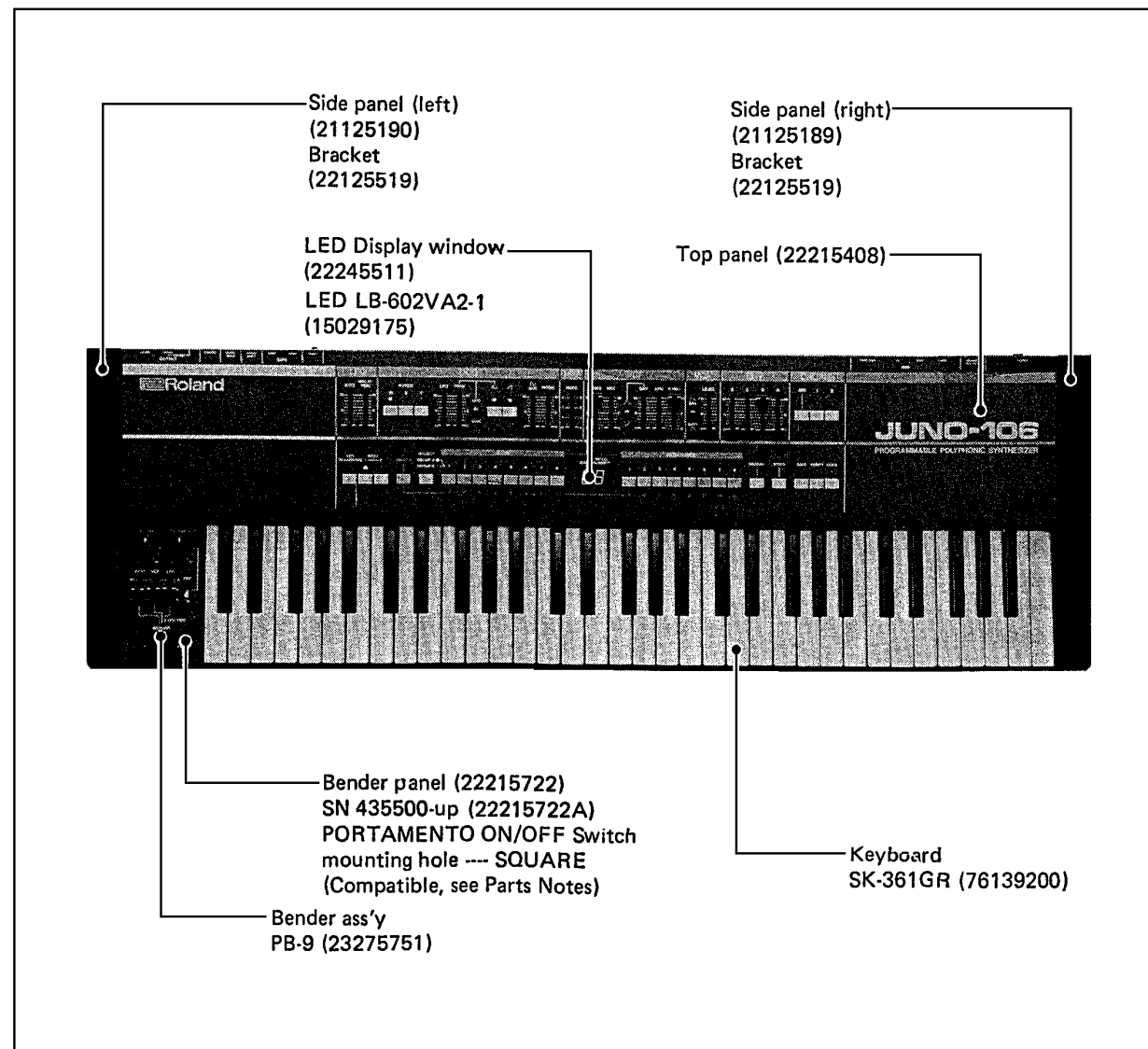

BLOCK DIAGRAM

1 2 3 4 5 6 7 8 9 10 11 12 13 14 15 16 17 18 19 20 21 22 23 24 25 26 27 28 29 30 31 32 33 34 35 36 37

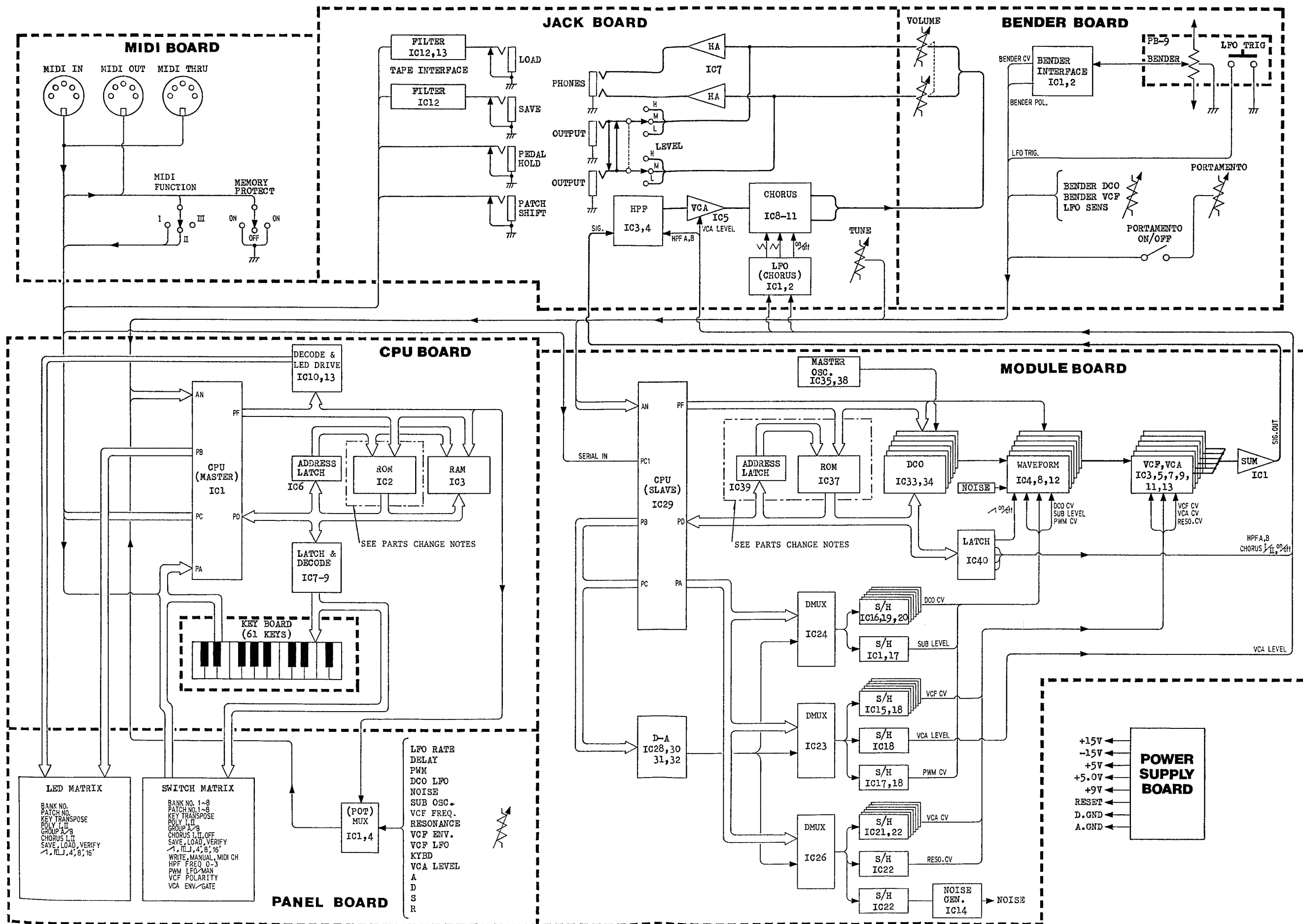

MODULE BOARD

Slave CPU μ PD7810/7811

DESIGNATION	PIN NO.	FUNCTION	
AN (ANALOG INPUT)	AN0 1	TUNE	
	2	PORTAMENTO	
	3	LFO TRIGGER SWITCH	
	4	LFO SENSE (DEPTH)	
	5	BENDER VCF SENSE	
	6	BENDER VCO SENSE	
	7	BENDER POLARITY	
PORT A	PA0 1	S/H DEMULTIPLEXER CHANNEL SELECT	
	2		
	3		
	4	NOT USED	
	5	S/H DEMULTIPLEXER CHIP SELECT	DCO CV
	6		VCF CV
	7		VCA CV
	8	NOT USED	
PORT B	PB0 9	D/A CONVERTER DATA OUT (UPPER 6 BITS)	
	1		
	2		
	3		
	4		
	5		
	6		NOT USED
PORT C	PC0 17	NOT USED	
	1	18	SERIAL DATA RECEIVE LINE (FROM CPU BOARD)
	2	19	D/A CONVERTER DATA OUT (LOWER 6 BITS)
	3	20	
	4	21	
	5	22	
	6	23	
7	24		
PORT D	PDO 55	ADDRESS LSB 8 BITS DATA OUT	
	1		
	2		
	3		
	4		
	5		
	6		
PORT F	PFO 47	ADDRESS MSB 6 BITS	
	1		
	2		
	3		
	4		
	5		RANGE SELECT
	6		
7	54		
XTAL-1	31	12MHz CLOCK INPUT	
XTAL-2	30		
RESET	28	RESET PULSE INPUT	
RD	44	ROM READ TIMING PULSE	
WR	45	8253 LATCH WRITE TIMING PULSE	
ALE	46	ADDRESS LATCH TIMING PULSE	
MODE 0	29	---- 1: EXTERNAL ROM, ---- 0: INTERNAL ROM	
MODE 1	27	---- 0: EXTERNAL ROM, ---- 1: INTERNAL ROM	

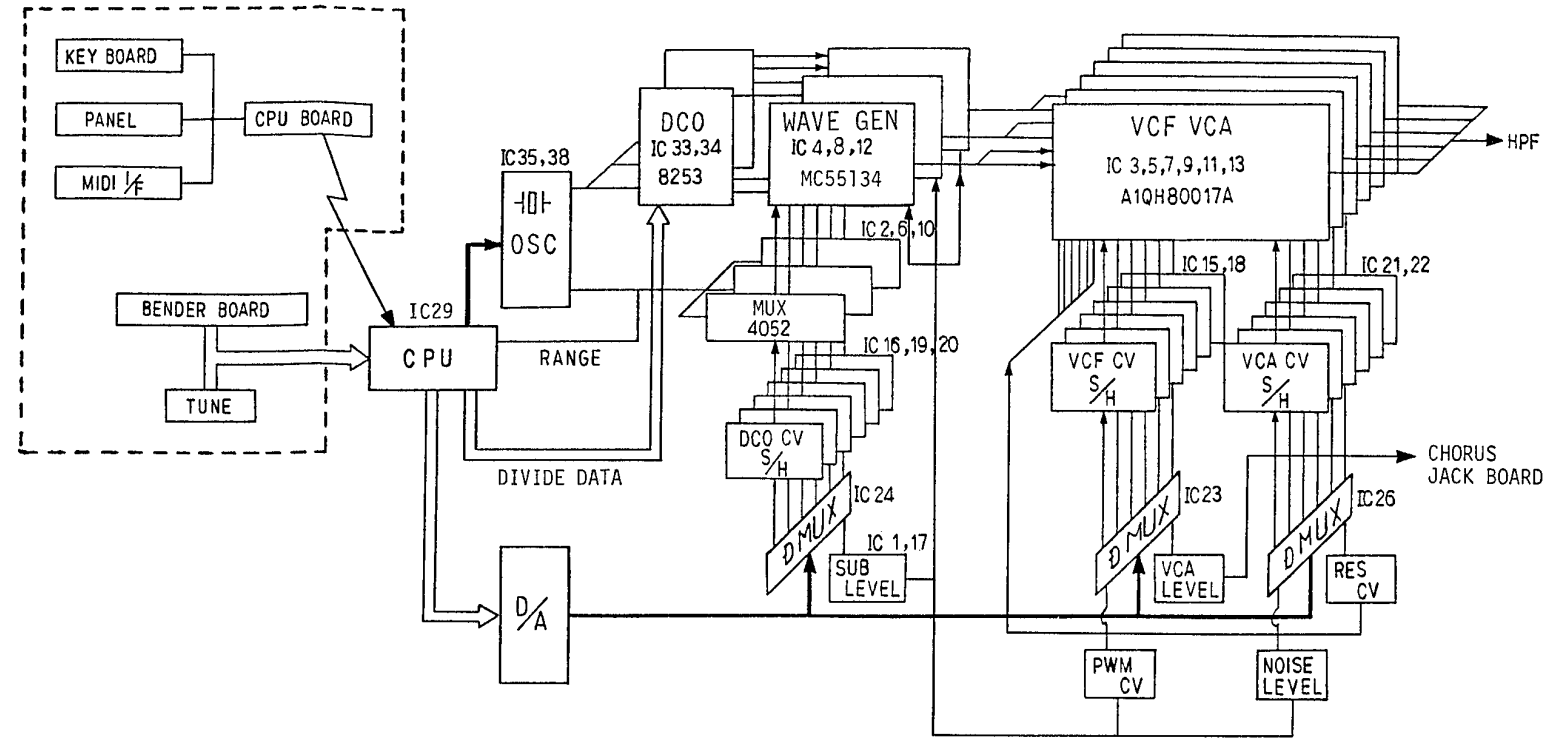

OSC, DCO

OSC

The oscillator consists of a master oscillator (8MHz) and a divider IC35. The IC35 divides 8MHz by two, four or eight according to a position of RANGE (4', 8', 16') on the panel and feeds it to DCOs IC33 and IC34 which are 16-bit Programmable Interval Timers.

DCO

Each of three counters in one Timer divides OSC frequency by a number defined by a divide data represented on the data bus of the slave CPU IC29. The

divide data is the sum of a key number and the outputs from LFO, Bender, Portamento and Tune for a particular note. The resultant at the output of each counter will be a rectangular of audio frequency.

D/A CONVERTER

In controlling voices the slave CPU does not output each parameter independently, rather, it integrates some of parameters that are needed for a particular destination (DCO, VCF or VCA) and represents them as a 12-bit data (upper 6 bits at PBO-PB5 and lower 6 bits at PC2-PC7). The data is converted into an analog voltage which is conditioned and routed to the destination module from the demultiplexer (IC23, 24 or 26) as shown below.

D/A & S/H TIMING CHART

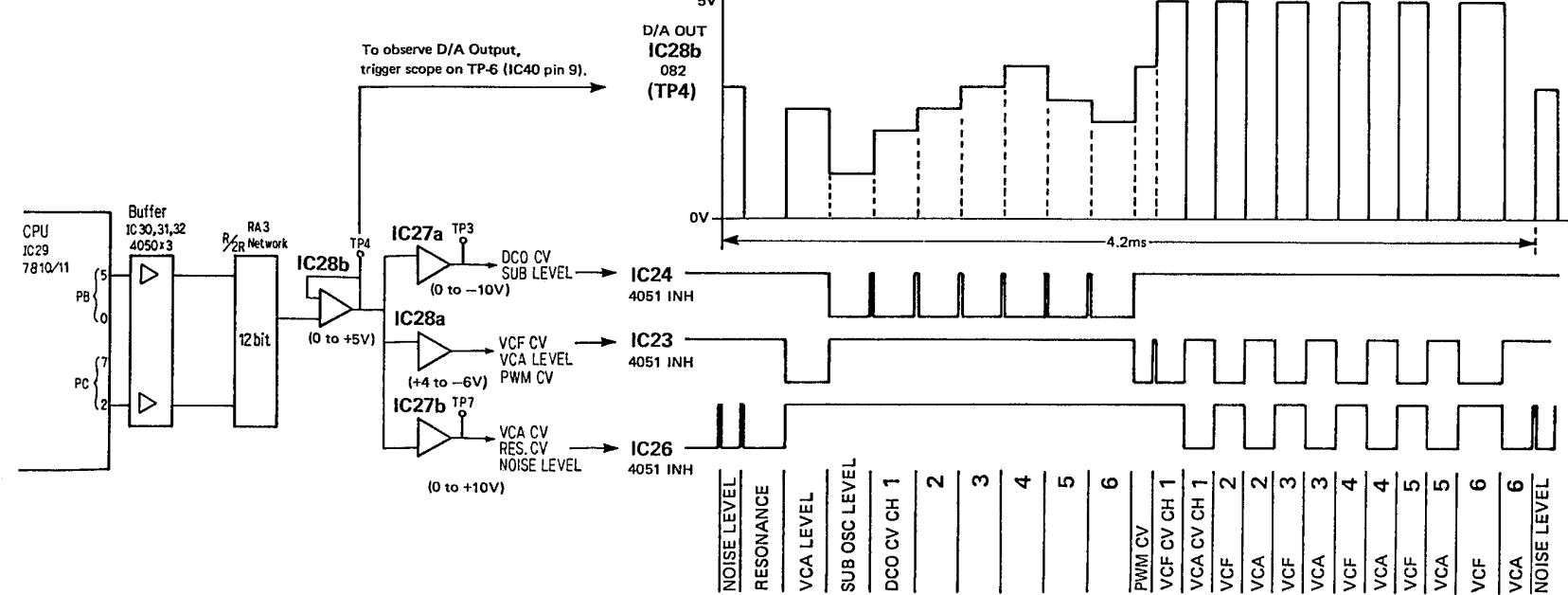

Note that the select code and INH for IC26 are level shifted at IC25 output. This is because that IC26 operates from $\pm 15V$.

WAVE GENERATOR

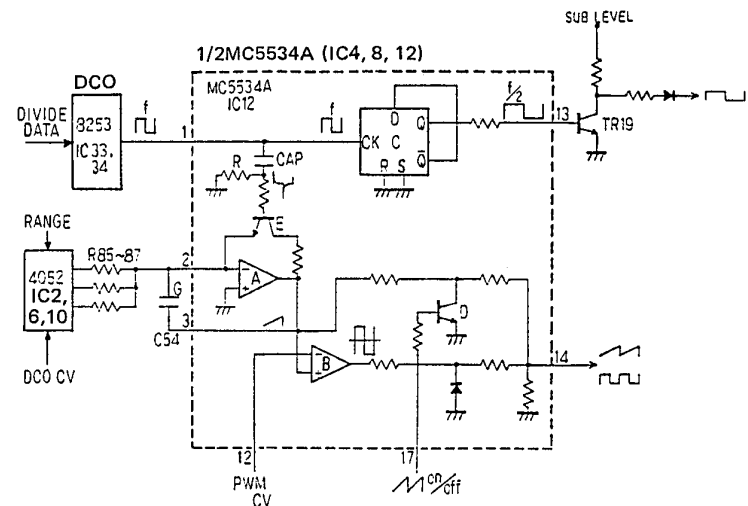

MC5534 (IC 4, 8 and 12) is, with a given rectangular at CLK IN, capable of generating three different waveforms; divided by two rectangular, sawtooth and variable-width rectangular (Pulse Width Modulated). There are three versions in MC5534 series; of these MC5534A is the latest version containing complete two identical circuits. See Parts Change Notes in the Parts List section for detail.

SUB OSCILLATOR

This is self-explaining from the figure. The output amplitude being variable to a change of collector supply voltage (SUB LEVEL).

SAWTOOTH

For sawtooth and PWM waveforms, DCO CV is applied from the slave CPU in addition to DCO output.

The DCO CV will keep the sawtooth and pulse amplitude nearly constant (approx. 12Vp-p) over the frequency range (detailed later). Therefore, DCO CV includes LFO, BENDER, PORTAMENTO and TUNE data as well as key value, but it does not contain RANGE data; the DCO CV sees RANGE at the output of 4052 (IC2, 6 or 10) which selects among R85, 86 and 87 in accordance with RANGE code (PF6 and 7 of the slave CPU). The DCO CV charges C54 through R85 (if 16') and discharges through transistor E on the positive going edges of DCO. If the RC time constant (C54 and R85, 86 or 87) remains unchanged, sawtooth amplitude becomes low at 4'. The same principle applies to key range over the keyboard; the output amplitude decreases as the note runs high. Therefore, DCO CV is made to become higher in proportion to key number.

PULSE MODULATED WAVE

At ICB input, sawtooth wave is compared with PWM CV that determines the pulse duration of ICB output; duty ratio is 50% at +6V PWM CV and 95% at +0.6V. With PWM OFF, PWM CV is -0.8V; this can swing and keep ICB output to High, disabling the rectangular.

VCF, VCA

A1QH80017A is a one-chip VCF and VCA. Both VCF and VCA are individually controlled by the several parameters integrated into one voltage: VCF CV contains CUT OFF (VCF) frequency, ENV, LFO, Key follow and Bender; VCA CV includes ENV and GATE.

IC DATA

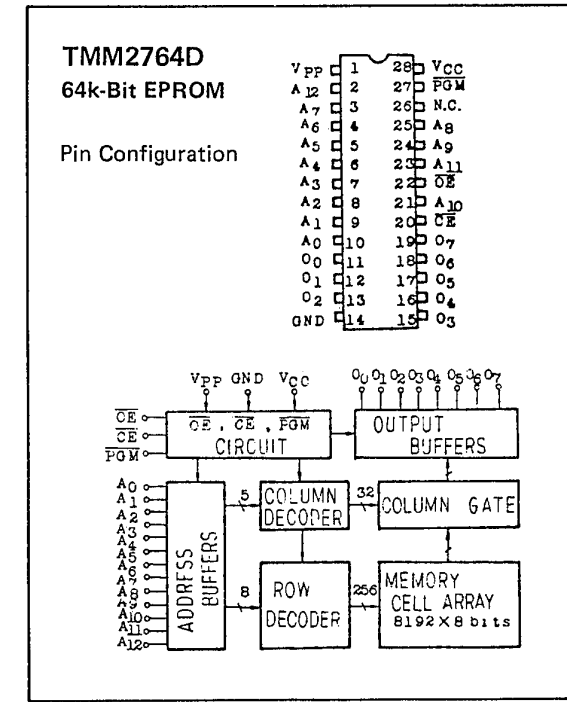
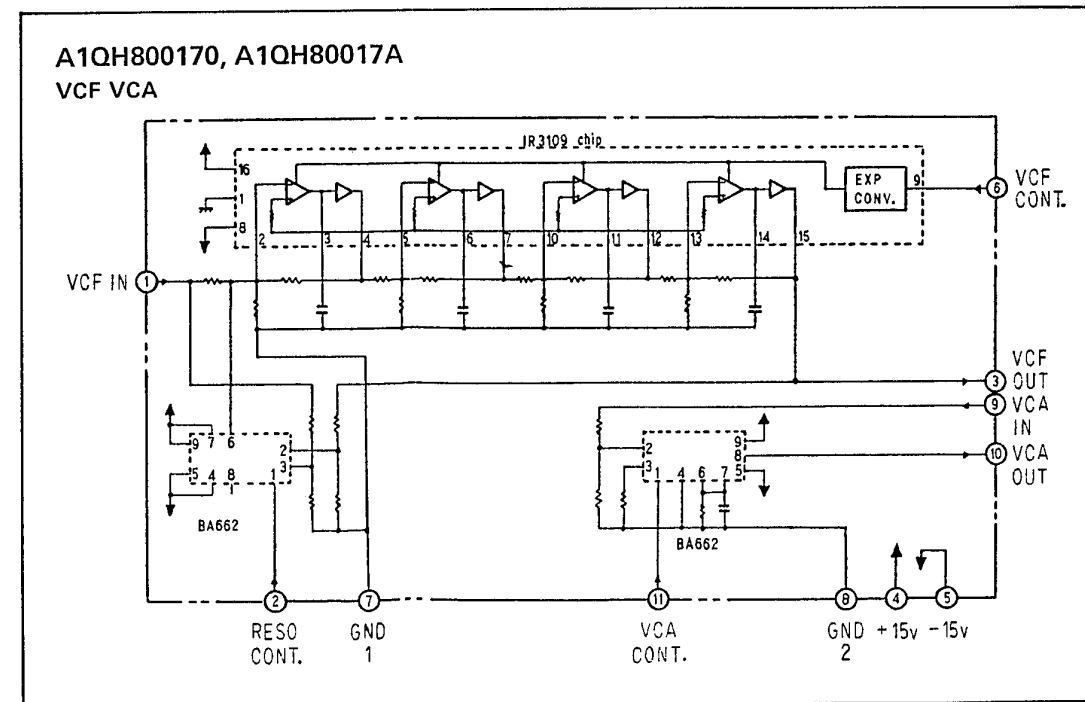
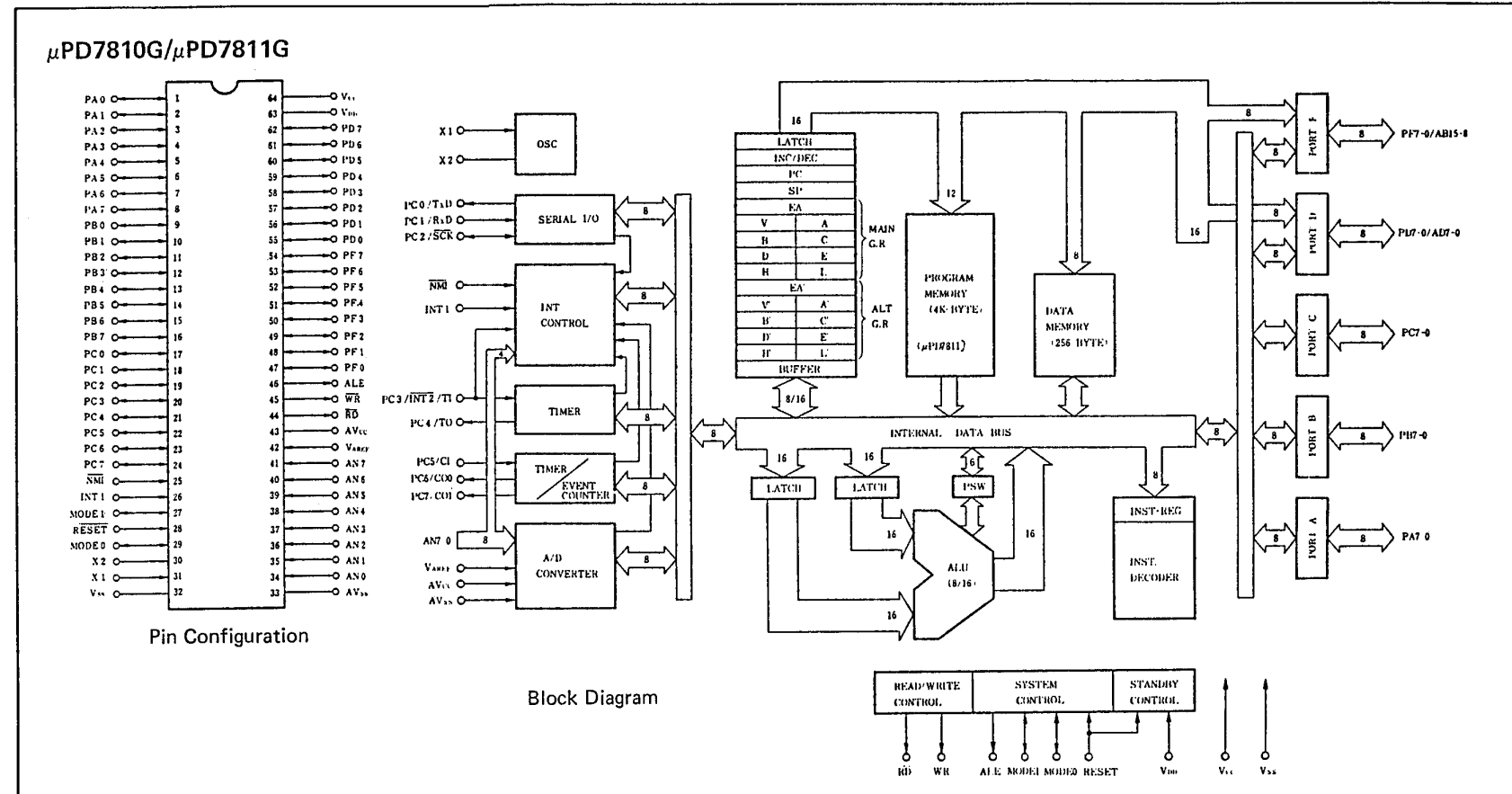

1 2 3 4 5 6 7 8 9 10 11 12 13 14 15 16 17 18 19 20 21 22 23 24 25 26 27 28 29 30 31 32 33 34 35 36 37 38 39

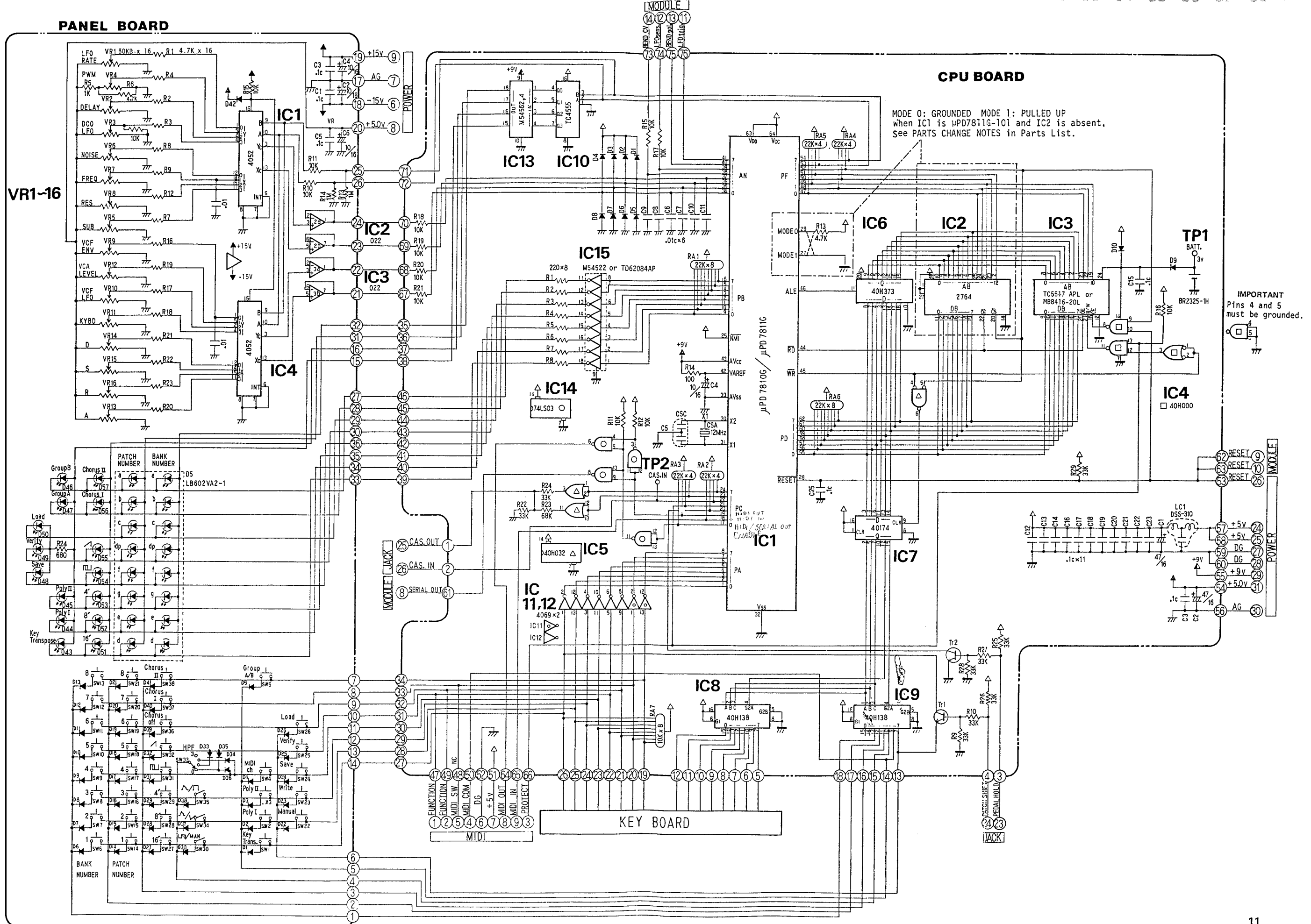

MODULE BOARD

76139170

(pcb 22915902)

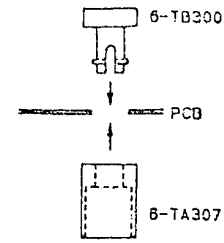

- Resistor R20J
- Metal oxide film resistor 1% 100ppm
- Posistor (560 ohm)
- Ceramic capacitor
- Mylar
- Electrolyte capacitor
- Non-polar electro capacitor
- Transistor 2SC-1815-Y or -1815-GR
- Transistor 2SA-1015-Y or -1015-GR
- Transistor 2SC-945P (selected for noise generator)
- Diode 1SS-133
- Trimmer pot, H0615C119
472: 4.7K 103: 10K 223: 22K
473: 47K 104: 100K

1 2 3 4 5 6 7 8 9 10 11 12 13 14 15 16 17 18 19 20 21 22 23 24 25 26 27 28 29 30 31 32 33 34 35 36 37 38 39

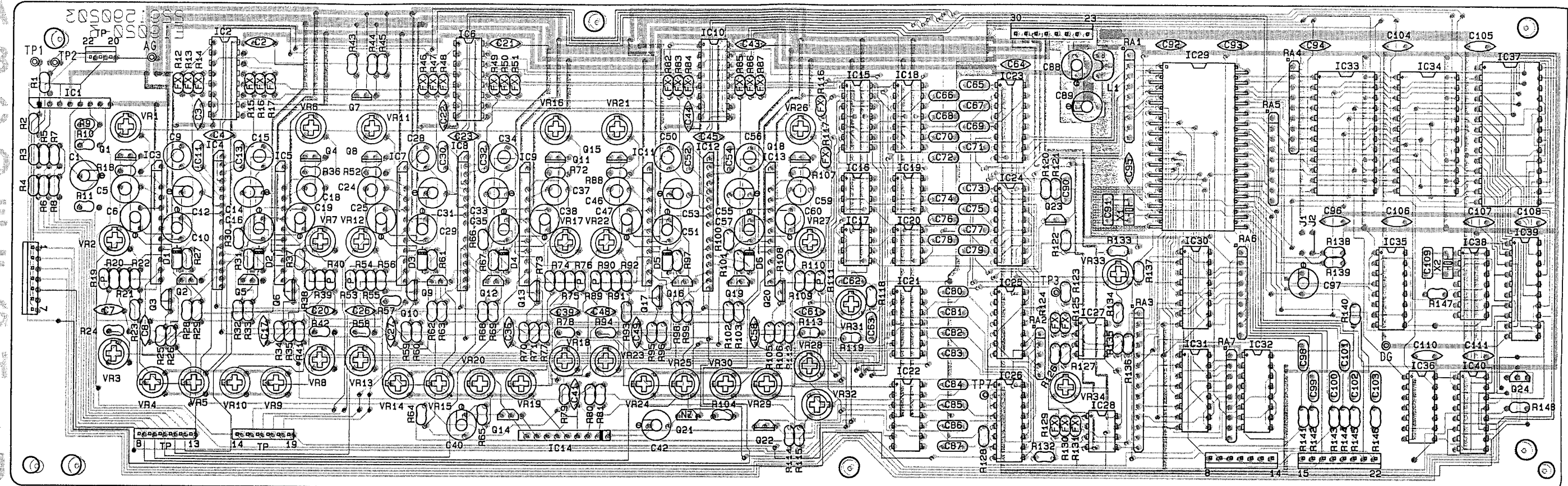

PARTS DESIGNATION
(in Dotted line, Schematic Diagram)

PCB 291-902
2291590203

CH1	R87	R86	R85	IC10.X	C43	C44	C53	R100	C55	C53	C45	Tr19	R101	D6	R102	R103	IC12	IC13	C56	Tr18	R107	VR26	R109	VR29	R110	R113	C61	VR28	C59	VR27	R108
CH2	R83	R84	R82	IC10.Y								Tr16	R97	D5	R99	R98		IC11	C50	Tr15	R88	VR21	R91	VR24	R90	R94	C48	VR23	C46	VR22	R92
CH3	R51	R50	R49	IC6.X	C21	C22	C32	R66	C33	C31	C23	Tr12	R67	D4	R68	R69	IC8	IC9	C34	Tr11	R72	VR16	R74	VR19	R75	R78	C39	VR18	C37	VR17	R73
CH4	R47	R48	R46	IC6.Y								Tr9	R61	D3	R63	R62		IC7	C28	Tr8	R52	VR11	R55	VR14	R54	R58	C26	VR13	C24	VR12	R56
CH5	R17	R16	R15	IC2.X	C2	C3	C13	R30	C14	C12	C4	Tr5	R31	D2	R32	R33	IC4	IC5	C15	Tr4	R36	VR6	R38	VR9	R39	R42	C20	VR8	C18	VR7	R37
CH6	R13	R14	R12	IC2.Y								Tr2	R27	D1	R29	R28		IC3	C9	Tr1	R18	VR1	R21	VR4	R20	R24	C7	VR3	C5	VR2	R22

CH1	R111	R112	VR30	Tr20	R105	R106	C58	R3	C60	C57	TP19	TP8
CH2	R89	R93	VR25	Tr17	R95	R96	C49	R4	C47	C51	TP18	TP9
CH3	R76	R77	VR20	Tr13	R70	R71	C36	R5	C38	C35	TP17	TP10
CH4	R53	R57	VR15	Tr10	R59	R60	C27	R6	C25	C29	TP16	TP11
CH5	R40	R41	VR10	Tr6	R34	R35	C17	R7	C19	C16	TP15	TP12
CH6	R21	R23	VR5	Tr3	R25	R26	C8	R8	C6	C10	TP14	TP13

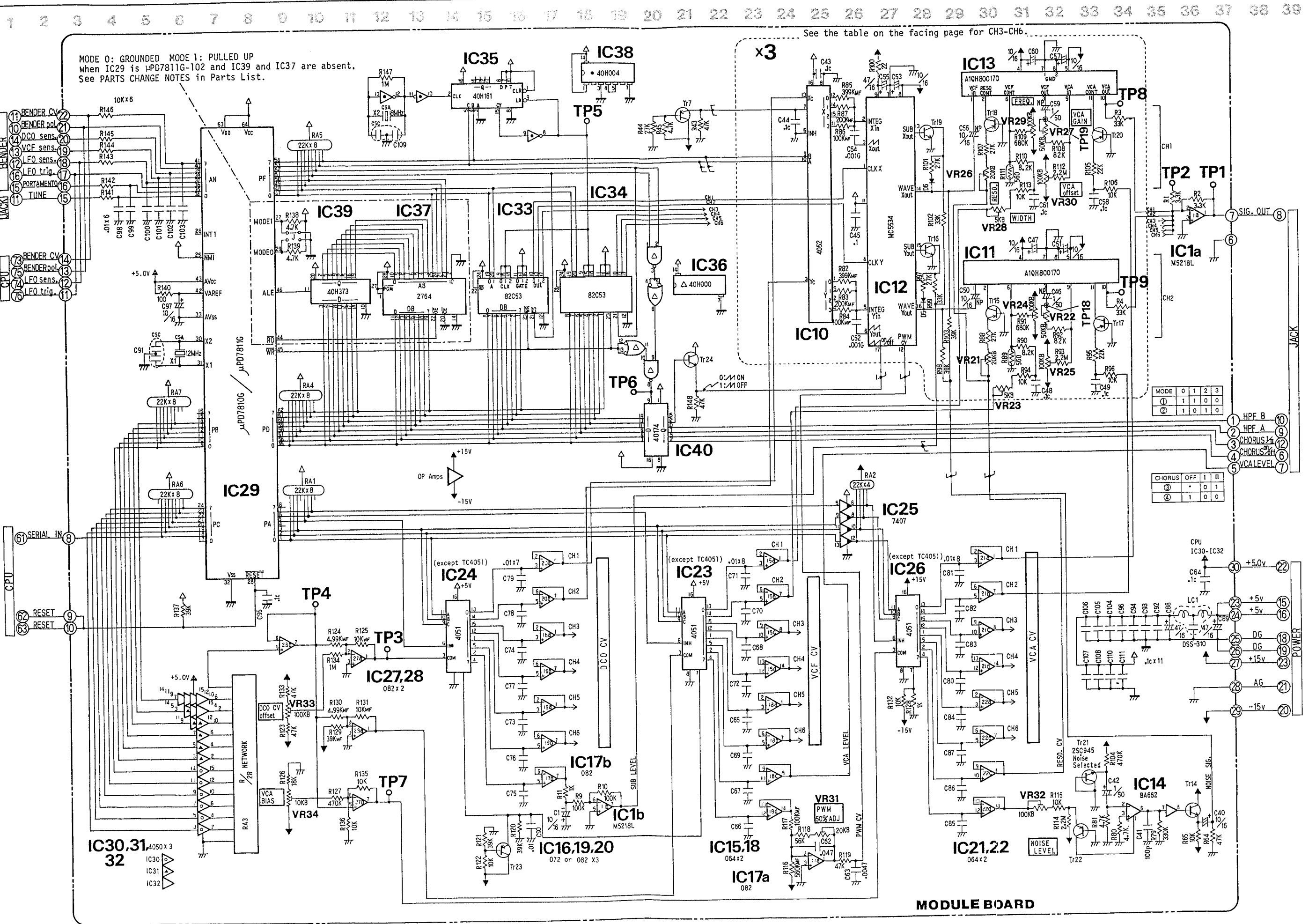

See the table on the facing page for CH3-CH6.

MODE 0: GROUNDED MODE 1: PULLED UP
When IC29 is μ PD7811G-102 and IC39 and IC37 are absent.
See PARTS CHANGE NOTES in Parts List.

MODE	0	1	2	3
①	1	1	1	0
②	1	0	1	0
③	1	0	0	0

CHORUS	OFF	I	II
③	*	0	1
④	1	0	0

MODULE BOARD

1 2 3 4 5 6 7 8 9 10 11 12 13 14 15 16 17 18 19 20 21 22 23 24 25 26 27 28 29 30 31 32 33 34 35 36 37 38

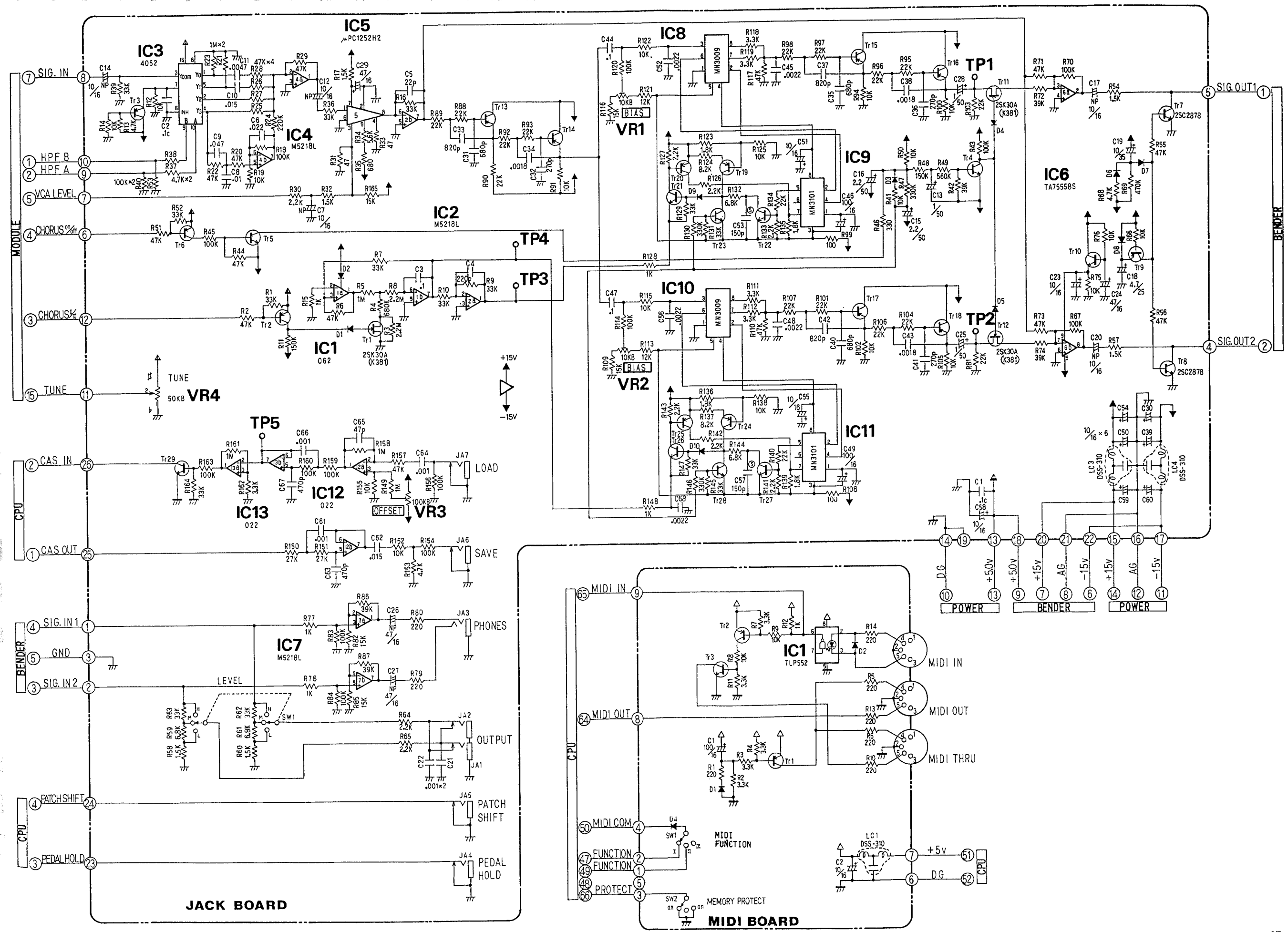

JACK BOARD

MIDI BOARD

1 2 3 4 5 6 7 8 9 10 11 12 13 14 15 16 17 18 19 20 21 22 23 24 25 26 27 28 29 30 31 32 33 34 35 36 37 38 39

BENDER BOARD

76139410 (pcb 22915899)

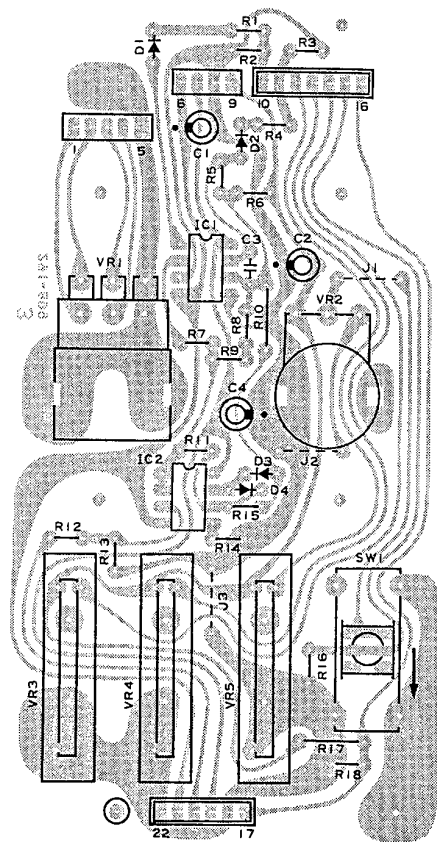

FUSE BOARD

76139111 100/117V (pcb 22915981)
76139114 220/240V (pcb 22915981)

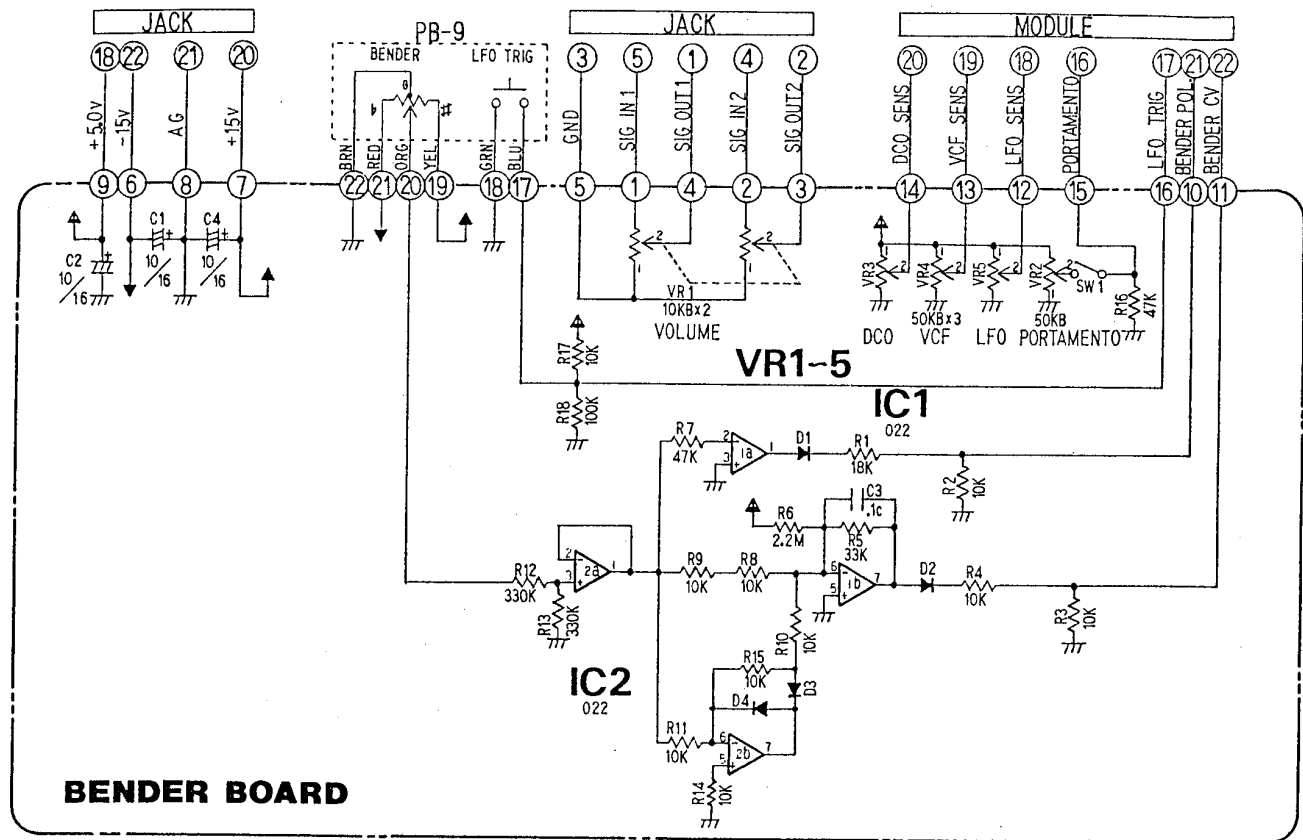
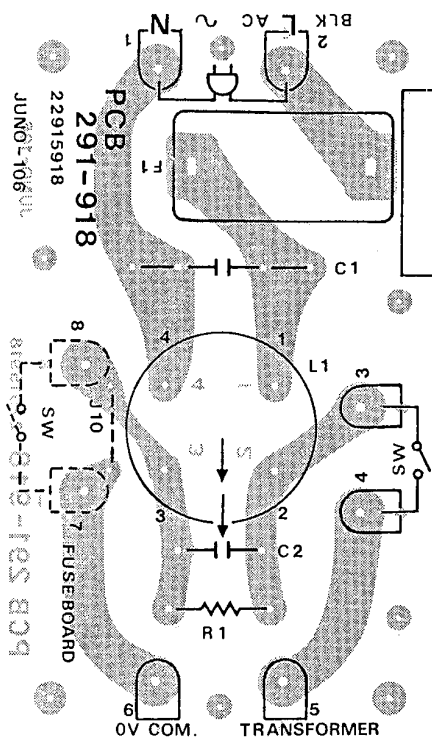

BENDER BOARD

POWER SUPPLY BOARD

76139121 100/117V (pcb 22915900)
76139124 220/240V (pcb 22915900)

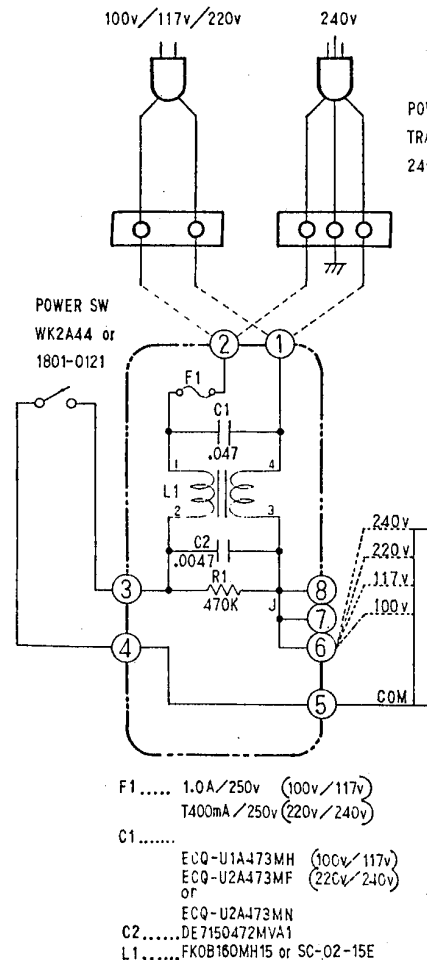
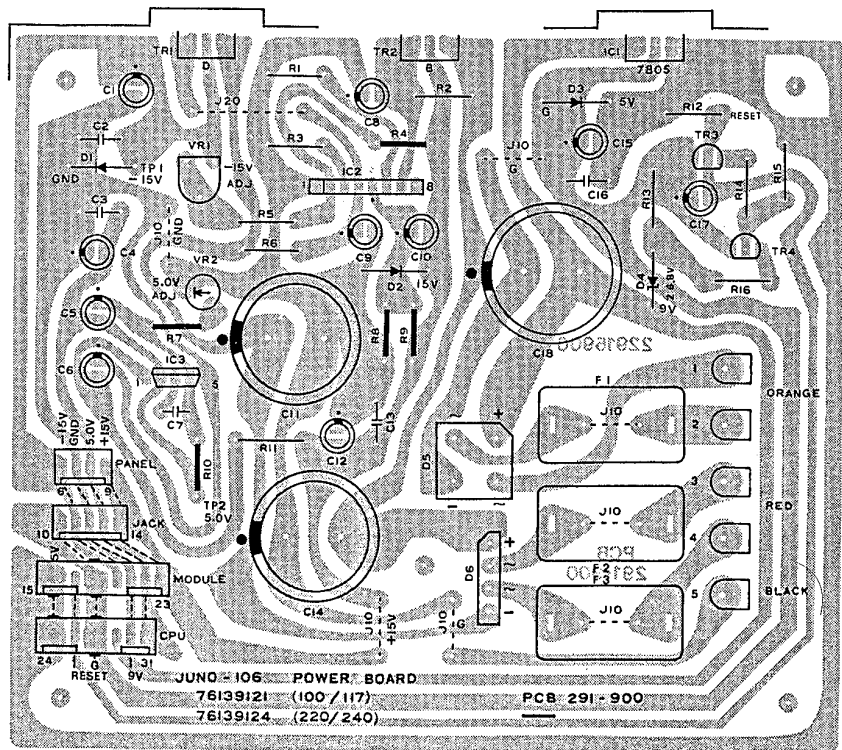

F1..... 1.0A/250v (100v/117v)
T400mA/250v (220v/240v)
C1..... ECQ-U1A473MH (100v/117v)
ECQ-U2A473MF (220v/240v)
or ECQ-U2A473MN
C2..... DE7150472MVA1
L1..... FK0B160MH15 or SC-02-15E

POWER SUPPLY BOARD

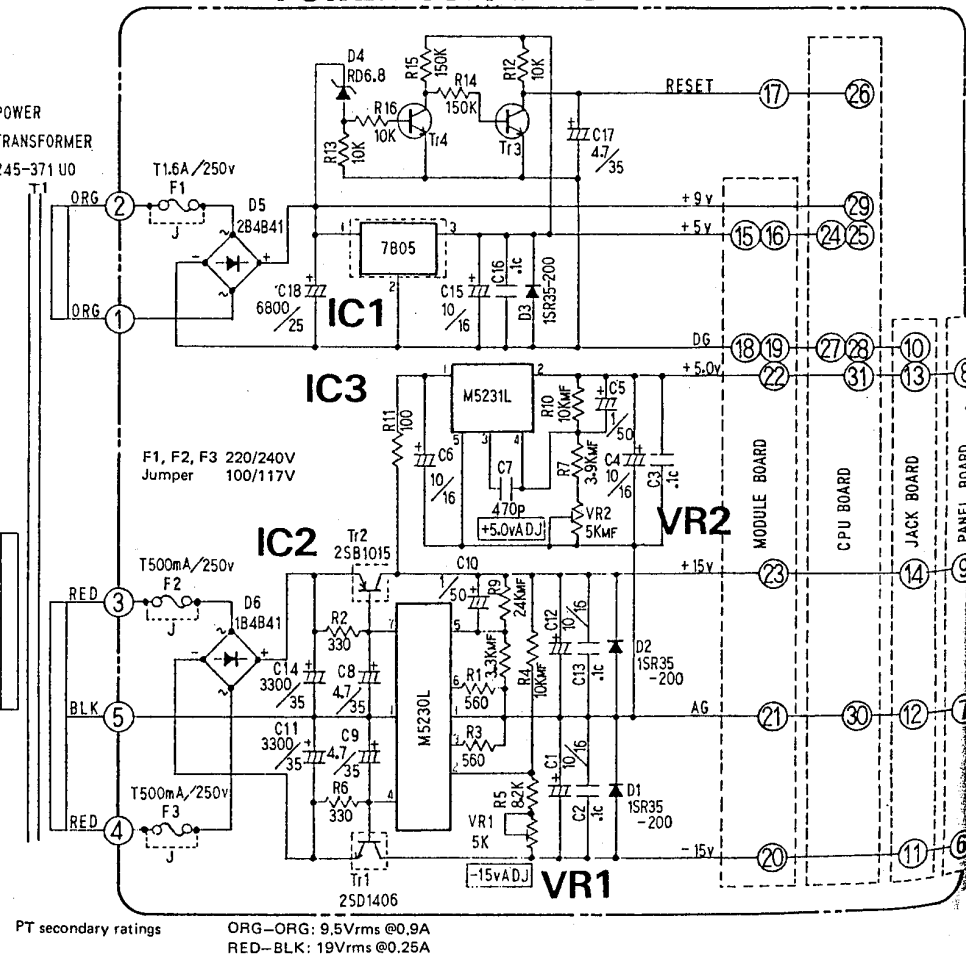

PT secondary ratings
ORG-ORG: 9.5Vrms @0.9A
RED-BLK: 19Vrms @0.25A

ADJUSTMENT

Adjustment must be performed in the order listed below.

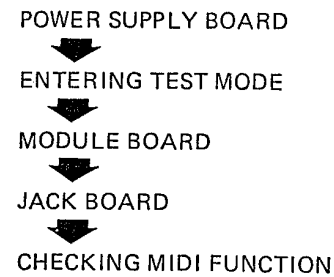

CAUTION

Allow at least 10 minutes for warmup period; mandatory upon VCF adjustments.

1. DC SUPPLY VOLTAGES (POWER SUPPLY BOARD)

CAUTION

Any slight adjustment on this board must be followed by a complete adjustment of the rest. Do not touch the trimmers inadvertently before checking the test points for voltage.

Test instrument: Digital voltmeter with 10mV resolution.

- 1-1. Adjust VR1 for $-15V \pm 10mV$ at (A).
- 1-2. Adjust VR2 for $+5V \pm 10mV$ at (B).
- 1-3. Verify $+15V \pm 0.8V$ at (C).
- 1-4. Verify $+5V \pm 0.5V$ at (D).

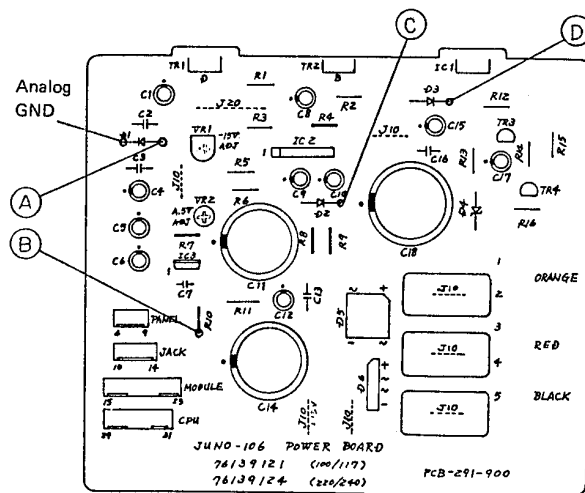

TEST PROGRAM

The following adjustments can be performed with the aid of Test Program stored in the CPU on the CPU Board.

To enter the test mode, hold KEY TRANSPOSE down and turn the JUNO-106 ON; the display window will

read indicating that the unit is in the test mode. During the test mode, each switch serves as follows:

SWITCH		FUNCTION DURING THE TEST MODE	
KEY ASSIGNMENT	POLY 1	UNISON:	All six modules are assigned simultaneously to a key being pressed.
	POLY 2	NON ROTARY:	The voices are assigned to the keys played in the order CH1 to CH6 as long as the previous keys are held down. One-key staccato always sounds CH1 only. The display window indicates currently assigned channel number.
	POLY 1 & POLY 2	ROTARY:	The voices are assigned in cyclic manner; 7th key steals the voice from the 1st key. The display window indicates current channel number.
BANK GROUP	GROUP A GROUP B	HOLD OFF HOLD ON	
TAPE CHECK LED	SAVE LED VERIFY LED	MIDI FUNCTION II CHECK MIDI FUNCTION I CHECK	
MIDI CH		Turns D/A output to 0V	

Pressing BANK buttons also evokes Test Program and sets the front panel controls as below. PATCH buttons have no effects in the test mode.

BANK NO.	TEST FUNCTION	LFO		DCO					H P F	VCF				VCA		ENV			C H O R U S						
		R A T E	D E L A Y	R A N G E	S U B	N O I S E	L F O	P W M		P W M M O D E	F R E Q	R E S O	E N V	E N V P O L A	L F O	K Y B D	L E V E L	A		D	S	R			
1	VCA OFFSET	5	0	8'			0	0	0	0	M	1	10	0	0	N	0	10		5	0	0	0	0	0
2	SUB OSC	5	0	8'			10	0	0	0	M	1	10	0	0	N	0	10		5	0	0	10	0	0
3	VCA GAIN VCF	5	0	8'			0	0	0	0	M	1	6.3	10	0	N	0	10		5	0	0	10	0	0
4		5	0	8'		ON	0	0	0	0	M	1	10	0	0	N	0	10		5	0	0	10	0	0
5	PWM 50%	5	0	8'	ON		0	0	0	0	M	1	10	0	0	N	0	10		5	0	0	10	0	0
6	NOISE LEVEL	5	0	8'			0	10	0	0	M	1	10	0	0	N	0	10		5	0	0	10	0	0
7	VCF HIGH LOW	5	0	8'			0	0	0	0	M	1	10	10	0	N	0	10		5	0	0	10	0	0
8	RE-TRIGGER	5	0	8'	ON		0	0	0	0	M	1	10	0	0	N	0	10		5	0	1.3	0	1.3	0

Not all TEST FUNCTIONS are involved in the adjustment.

Edit functions also are active in test mode; when an edit is made, display window lights a dot. To return to the test mode, press the same BANK button again.

2. DCO CV OFFSET (MODULE BOARD)

Test instrument: Voltmeter (1mV resolution)
 Test point: TP3
 Key assignment: POLY 1 (UNISON during test mode).

- 2-1. Press MIDI CH button; D/A converter turns its output to 0V.

CAUTION

Pressing any key on the keyboard releases MIDI CH, letting the D/A to develop voltage according to that key. Press MIDI CH again to defeat the key voltage.

- 2-2. Adjust VR33 for 0V reading.
- 2-3. Leave MIDI CH ON for the next adjustment 3.

3. VCA BIAS (MODULE BOARD)

Test instrument: Voltmeter (1mV resolution)
 Test point: TP7
 Key assignment: POLY 1 (UNISON during test mode).

- 3-1. Press MIDI CH. Refer to "CAUTION in 2-1".
- 3-2. Adjust VR34 for a reading within $+0.25V$ to $+0.27V$.

4. VCA OFFSET (MODULE BOARD)

Test instrument: Oscilloscope
 Test point: TP8 (CH1) to TP13 (CH6)
 BANK: 1
 Key assignment: POLY 1 (UNISON during test mode)

- 4-1. Adjust the following trimmers, respectively, for the minimum thumps.

VR NO.	30	25	20	15	10	5
CH NO.	1	2	3	4	5	6

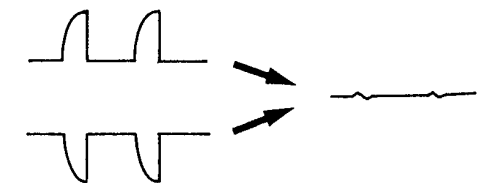

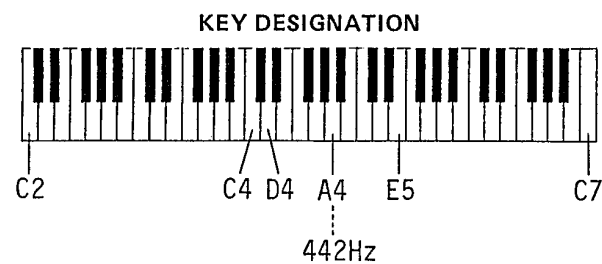
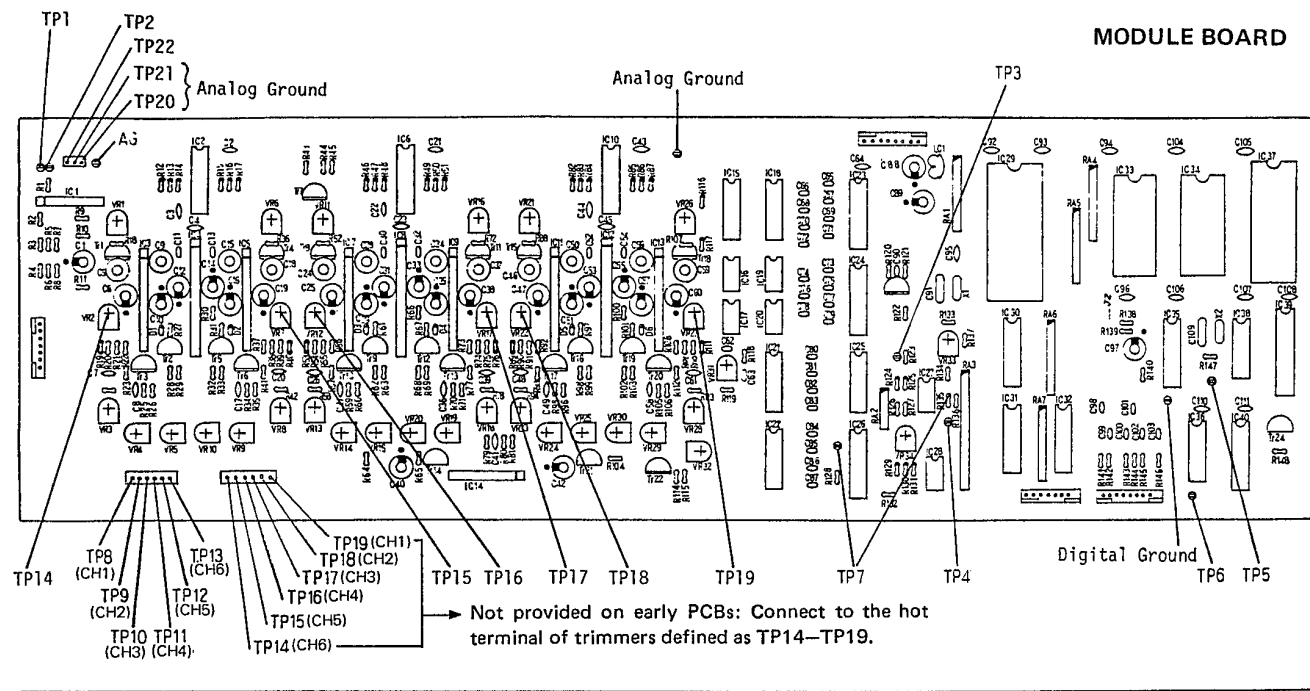

5. VCF RESONANCE (MODULE BOARD)

CAUTION

This adjustment must be done after 10 minutes has passed and after 3. VCA BIAS has been finished.

Test instrument: Oscilloscope
 Test point: TP19 (CH1) to TP14 (CH6)
 Key assignment: POLY 1 (UNISON during test mode).
 BANK: 3

5-1. While holding down C4 key, adjust the trimmers listed below, respectively, for 4.8Vp-p sine wave.

VR NO.	26	21	16	11	6	1
CH NO.	1	2	3	4	5	6

6. VCA GAIN (MODULE BOARD)

CAUTION

This adjustment must follow 5. VCF RESONANCE.

Test instrument: Oscilloscope
 Test point: TP8 (CH1) to TP13 (CH6)
 Key assignment: POLY 1 (UNISON during test mode)
 BANK: 3

6-1. While holding down C4 key, adjust the following trimmers, respectively, for 6Vp-p sinewave.

VR NO.	27	22	17	12	7	2
CH NO.	1	2	3	4	5	6

7. VCF FREQUENCY (MODULE BOARD)

CAUTION

This adjustment must be performed after 10-minute warmup has passed.

Test instrument: Frequency counter or Tuner
 Test point: TP8 (CH1) to TP13 (CH6), or OUTPUT
 Key assignment: POLY 1 (UNISON during test mode) or POLY 1 + POLY 2 (ROTARY during test mode) -- when checking at OUTPUT
 BANK: 3

7-1. While holding C4 key, adjust the trimmers listed below, respectively, for 248Hz (B3 pitch).

VR NO.	29	24	19	14	9	4
CH NO.	1	2	3	4	5	6

8. VCF WIDTH (MODULE BOARD)

CAUTION

Perform this adjustment after at least 10-minute warm-up.

Test instrument: Frequency counter or Tuner
 Test point: TP8 (CH1) to TP13 (CH6), or OUTPUT (tuner method)
 Key assignment: POLY 1 or POLY 1 + POLY 2 (OUTPUT)
 BANK: 3

8-1. Holding C6 key down, adjust each trimmer listed below respectively for 992Hz (equal to B5 note).

VR NO.	28	23	18	13	8	3
CH NO.	1	2	3	4	5	6

NOTE: Procedures 7 and 8 interact. Repeat the steps in both paragraphs until satisfactory result is obtained (within ± 10 cents on the tuner).

9. NOISE LEVEL (MODULE BOARD)

CAUTION

6. VCA GAIN must have been finished before this adjustment is performed.

Test instrument: Oscilloscope
 Test point: TP8
 Key assignment: POLY 1
 BANK: 6

9-1. Holding any key on the keyboard down, adjust VR32 for 4Vp-p on the scope.

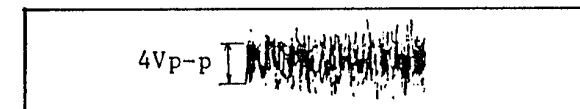

10. PWM (MODULE BOARD)

CAUTION

2. DCO CV OFFSET must have been finished.

50%

Test instrument: Oscilloscope
 Test point: TP8 (CH1) to TP13 (CH6)
 Key assignment: POLY 1
 BANK: 5

10-1. While holding C4 key down, adjust VR31 for a 50% duty cycle.

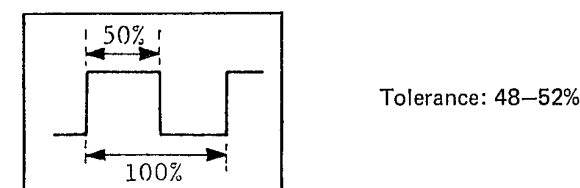

10-2. Confirm that the duty cycles of the rest channels (TP9 - TP13) are within 48 - 52%.

95%

10-3. Holding C4 key down, confirm that duty cycle of all channels are within 93 - 97% with PWM set at 10.

NOTE: If, incidentally, the PWM knob has been set at 10, lower it then raise to 10 again.

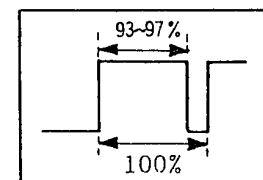

JACK BOARD

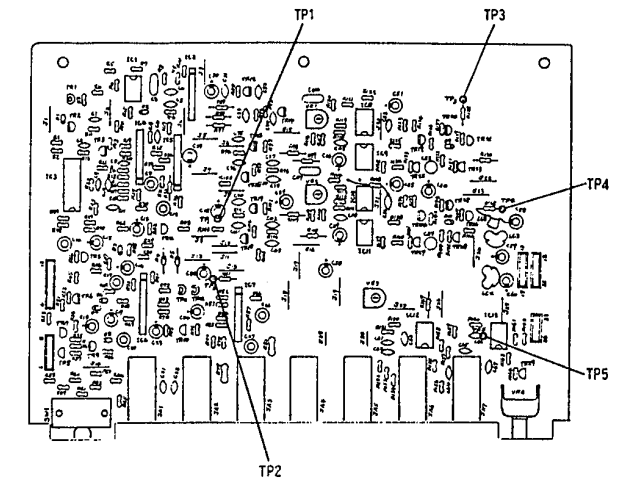

11. CHORUS BIAS (JACK BOARD)

Test instrument: Oscilloscope, Audio generator
 Test point: TP1 (CH1), TP2 (CH2)
 VCA LEVEL: 0
 CHORUS: I

11-1. Feed 10Vp-p, 1kHz, sine wave into TP2 of the MODULE BOARD.

11-2. Adjust VR1 (CH1) and VR2 (CH2) on the JACK Board respectively so that positive and negative halves are symmetrical with respect to the center horizontal line.

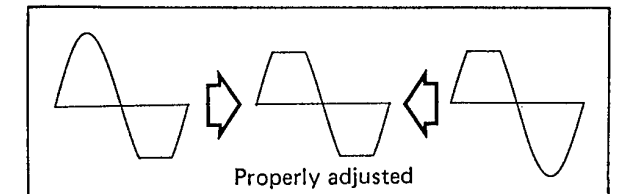

12. LOAD OFFSET (JACK BOARD)

Test instrument: Voltmeter with 1mV resolution
 Test point: TP5

12-1. Adjust VR3 for 0mV reading.

13. MIDI FUNCTION SWITCH CHECK

13-1. Verify the following with FUNCTION set at respective position.

- I: only VERIFY LED lights
- II: only SAVE LED lights
- III: no LEDs light

